



Analysis of angiotensin II receptor antagonist and protein markers at microliter level plasma by LC–MS/MS

Chi-Yu Lu^{a,b,c}, Yung-Ming Chang^d, Wei-Lung Tseng^b, Chia-Hsien Feng^{e,*}, Chin-Yuan Lu^f

^a Department of Biochemistry, College of Medicine, Kaohsiung Medical University, Kaohsiung, Taiwan

^b National Sun Yat-Sen University-Kaohsiung Medical University Joint Research Center, Kaohsiung, Taiwan

^c Center of Excellence for Environmental Medicine, Kaohsiung Medical University, Kaohsiung, Taiwan

^d Division of Cardiovascular Medicine, Department of Internal Medicine, Changhua Christian Hospital, Changhua, Taiwan

^e Department of Fragrance and Cosmetic Science, College of Pharmacy, Kaohsiung Medical University, Kaohsiung, Taiwan

^f Department of Radiological Technology, Central Taiwan University of Science and Technology, Taichung, Taiwan

ARTICLE INFO

Article history:

Received 13 July 2008

Received in revised form

27 September 2008

Accepted 30 September 2008

Available online 10 October 2008

Keywords:

Greener approach

Tandem mass spectrometry

Nanospray

Microliter level

Waste reduction

ABSTRACT

An analytical method based on a green approach is proposed for clinical analysis. The proposed procedure involves the reduction of the sample preparation steps, the amounts of reagents and organic solvents. This simple and sensitive method for the analysis of clinical drug and biomarkers in human plasma was developed using LC connected to tandem mass spectrometry (LC–MS/MS) with a nanospray ion source. In this study, the desired drug and proteins were separated on a 5 and 10 cm RP C18 nano-flow column. Undesired polar substances in human plasma were washed out by using ACN:1% FA = 20:80 (v/v) as the loading mobile phase for drug analysis and good linearity was attainable. Only a small volume of human plasma (10 μ L) was utilized for the monitoring of drug plasma concentration and significant proteins under clinical studies. All the sample preparation procedures and the analytical scheme were at microliter level. This strategy would lower the consumption of reagents and organic solvents and make a contribution toward the goal of reduction of pollution from analytical methods in general.

© 2008 Elsevier B.V. All rights reserved.

1. Introduction

In this study, we applied the chemical waste reduction approach while developing a method for monitoring angiotensin II type 1-receptor blockers (ARBs) and related proteins. The renin-angiotensin system (RAS) plays an important role in control of blood pressure. The main effector of RAS is angiotensin II that is transformed from angiotensin I through the angiotensin-converting enzyme (ACE) action rapidly. The functions of angiotensin II cause vasoconstriction and retention of sodium and fluid by binding its type 1(AT1) receptors. ARBs have been used for treatment of hypertension and heart failure. The major disadvantage of the ARBs is their association with persistent or even lethal fetotoxic defects when used during the late second or third trimester [1–3]. ARBs are a very popular medicine in the treatment of essential hypertension. Valsartan (Diovan[®]) is one such ARB, and the peak plasma concentration of valsartan after oral administration (160 mg) is between 2 and 4 μ g/mL [4].

Several high-performance liquid chromatographic (HPLC) methods coupled with fluorescence [4–9] or ultraviolet detec-

tion [10–16] in the determination of the different ARBs. Several capillary electrophoresis (CE) separations have been carried out recently [13,17–22]. The main drawback of CE is its low concentration sensitivity, which is due to small injection volume and small optical path-length. Thus, these methods usually need pre-concentration procedures to increase sensitivity. The biosample pretreatment methods for ARBs are usually solid-phase extraction (SPE) [6,10,16,23,24], liquid–liquid extraction [5,7] or protein precipitation [4,8,9,22,25,26].

Traditional HPLC methods are reliable techniques and are widely used for analysis of chemicals. The major demerit is that much solvent waste is produced. The capillary LC method resembles traditional HPLC in principle, and technicians will be familiar with this new method. The current trend in the world is towards eco-awareness and this is a green analytical method. Recently, LC-combined tandem mass spectrometry (LC–MS/MS) has become a powerful tool for biosample analysis. Several mass spectroscopic methods are used for detection of ARBs [23–28], but the only study described by Koseki et al. was for valsartan analysis [23]. Koseki used the SPE method for sample preparation, but this procedure is very complicated and time consuming.

Proteomic technology is a powerful strategy for identifying proteins and their interactions in cells and body fluids. Complex protein mixtures have been identified by this modern technol-

* Corresponding author. Tel.: +886 7 312 1101x2805; fax: +886 7 321 0683.
E-mail address: chfeng@kmu.edu.tw (C.-H. Feng).

ogy [29,30] and today much biological or biomedical research focuses on biomarker screening for the purpose of disease diagnosis [31]. For protein identification proteins become small peptides by tryptic digestion and peptide mixtures could be separated by capillary column with capillary or nano-flow LC. LC-MS/MS combined with database searching is a high throughput and efficient technique for protein identification [32–34]. Traditional proteins are digested with trypsin to produce peptides, two-dimensional gel electrophoresis (2D GE) can be used to separate several hundreds of proteins in one gel; however, the separation is rather time-consuming.

In this paper, we have developed a simple analytical method for the analysis of valsartan in human plasma. The sample preparation was based on simple protein precipitation steps. According to this strategy, the hypotensive drugs were retained on the hydrophobic stationary phase of the nano-flow column. Then the analytes were separated in the reversed-phase (RP) nano-flow column and eluted to the nanospray source. After simple deproteinization and centrifugation of the human plasma samples, an aliquot of 1 μL supernatant was injected into the chromatographic system. The method was successful in monitoring the valsartan levels within a therapeutic range. Only 10 μL of human plasma sample is required for clinical testing. Application of this solvent saving method for the analysis of ARBs in biological samples is workable. After detecting the valsartan concentration, 10 μL of human plasma were used for a proteomics study to screen for important biomarkers. After removal of albumin, the plasma proteins were precipitated and then subjected to an in-solution digestion over night. Then those peptide mixtures were separated and identified by peptide sequencing. We could monitor the plasma concentration of the hypotensive drug and detect the hypertensive-associated proteins by LC-MS/MS. All sample preparation and analytical procedures were conducted at microliter level. Green analytical chemistry is a new approach to chemical analysis [35]. The principles of this approach include primary elimination or at least reduction of the amounts of reagents and solvents during laboratory work, particularly at the sample preparation stage [35]. Over the course of the past decade, green chemistry has demonstrated how fundamental scientific methodologies can protect human health and the environment, in an economically beneficial manner [36].

2. Materials and methods

2.1. Materials

Valsartan was obtained as a gift from Novartis Pharma (Basel, Switzerland). Losartan potassium (internal standard, IS) was a gift from Merck-Frosst Pharmaceuticals (Rahway, NJ, USA). Acetonitrile (ACN), methanol, acetone, ammonium bicarbonate and formic acid (FA) purchased from Merck (Darmstadt, Germany) were of chromatographic grade. Heptafluorobutyric acid (HFBA), dithiothreitol (DTT) and iodoacetamide (IAA) were obtained from Aldrich (Milwaukee, WI, USA). Deionized water from a Milli-Q system, Millipore (Bedford, MA, USA), was used at all times. A stock solution of valsartan (1 mg/mL) was prepared by dissolving the compound in methanol. A HFBA solution was prepared by adding HFBA to deionized water to give a concentration of 100 g/L. An aqueous solution of FA was prepared by adding FA to deionized water to give a concentration of 1% (v/v) and 0.1% (v/v). Modified trypsin was purchased from Promega (Madison, WI, USA). The dealbumin kit "ProteoSpin" was purchased from Norgen Biotek Corporation (Thorold, ON, Canada).

2.2. Instrumentation

Tandem mass spectra were acquired using a Waters/Micromass quadruple time-of-flight (Q-TOF) Global Ultima mass spectrometer with a nanospray source (Manchester, UK). The system comprised of three microliter level pumps (pump A, B and C), an autosampler, an inline degasser, a sample cooler, a syringe pump and a switch valve. The separation was performed on Micro-tech Scientific Inc. (Vista, CA, USA) 5 (for valsartan analysis) and 10 cm (for peptide analysis) RP C18 nano-flow column (150 μm inner diameter; 375 μm outer diameter; 3 μm particle size). A desalting column (C18 PepMap, 300 μm i.d., 5 mm) used for peptide enrichment and trapping was purchased from LC Packings (Sunnyvale, USA).

2.3. LC-MS/MS conditions for valsartan analysis

The diagram of the nano-scale analytical system applied in this work is shown in Fig. 1. Sample injection was carried out by autosampler. The system comprised of three low flow-rate pumps at microliter level without flow splitter. For sample loading, the mobile phase of the pump A was ACN:1% FA = 20:80 (v/v) at a flow rate of 3 $\mu\text{L}/\text{min}$. For sample analysis, the mobile phase of the pump B: pump C were 1% FA:ACN = 20:80 (v/v) at a flow rate of 1 $\mu\text{L}/\text{min}$. To optimize the analytical methods, the standard compounds in methanol were continuously injected into the mass spectrometer using a syringe pump. The eluent was directed to the nanospray source with 20 μm i.d. \times 90 μm o.d. fused silica capillary. The mass spectrometer operated in positive ion mode with a source temperature of 80 $^{\circ}\text{C}$ and a cone voltage of 80 V. A voltage of 3.2 kV was applied to the source capillary. The desired molecular masses $[M + H]^+$ of valsartan and losartan (IS) selected for collision-induced dissociation (CID) were 436 and 423, respectively. Valsartan and IS were structural analogues and the MS/MS fragments of IS was

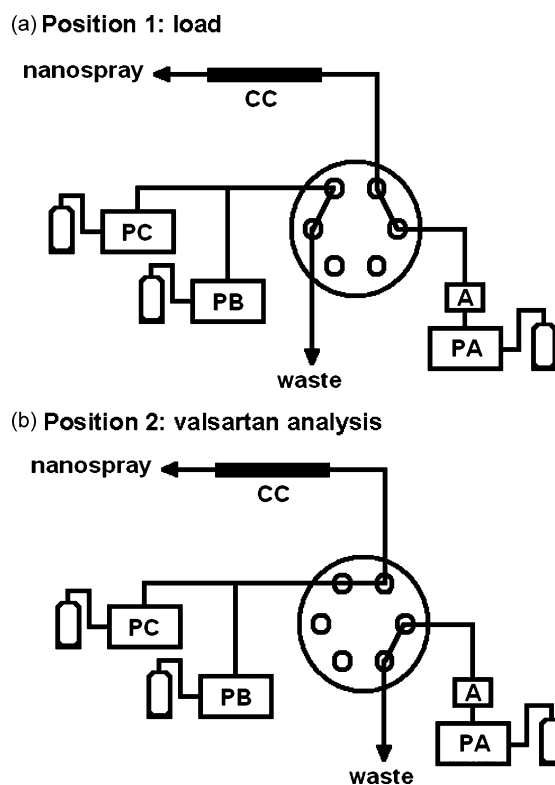

Fig. 1. The nano-scale analytical system for valsartan analysis: A = autosampler; CC = nano-flow capillary column (5 cm); PA = pump A; PB = pump B; PC = pump C.

reported by Zhao et al. [27]. MS/MS spectra were collected for each of these precursor ions by MS/MS scan mode of the scan function. The collision gas was argon and the collision energy was set at 20 eV during the MS/MS scans. MS/MS spectra were collected and processed by using MassLynx 4.0 software (Waters-Micromass).

2.4. Sample preparation for valsartan analysis

The sample preparation procedure in this study was very simple, just deproteinization and centrifugation. IS (10 µg/mL) was prepared by dissolving losartan in 100 g/L HFBA. Drug-free human plasma samples were spiked with five different levels of valsartan solution (Section 2.1) to prepare the final valsartan concentrations in human plasma over the range of 0.2–10 µg/mL for analytical calibration. Human plasma samples (10 µL) were added in Eppendorf vials (500 µL) and then IS solution (5 µL) was added. The sample vials were vortexed (30 s) and centrifuged at 10,000 rpm (2 min). After centrifugation, 1 µL of the supernatant were subjected to nano-scale LC–MS/MS.

2.5. Sample preparation for protein analysis

The dealbumin protocol was adapted as described by the kit's manufacturer. Briefly, the spin column was activated by "column activation and wash buffer". Then human plasma sample (10 µL) was mixed with "column activation and wash buffer" (490 µL) and sample was applied the 500 µL of diluted plasma sample onto the activated column. After column wash step, approximately 70% of albumin was depleted from the plasma sample. The dealbumin solution was collected and neutralized. For protein precipitation, 100 µL dealbumin solution was mixed with 1000 µL acetone, vortexed (30 s) and centrifuged at 10,000 rpm (10 min). After centrifugation, the supernatant was discarded and the protein pellets were evaporated to dryness. Then 100 µL ammonium bicarbonate (25 mM) was added to re-dissolve the protein residues. An aliquot of 16 µL this protein solution and 2 µL of 20 mM DTT (in 25 mM ammonium bicarbonate) solution were added in Eppendorf then kept at 25 °C for 30 min. After reduction the disulfide bonds of proteins, 2 µL of 25 mM IAA (in 25 mM ammonium bicarbonate) solution was added and kept at 25 °C in the dark for 30 min. Finally a freshly prepared solution of 2.5 µL sequence-grade modified trypsin (20 ng/µL in a 25 mM ammonium bicarbonate buffer) was added and kept at 37 °C for 16 h. After digestion, 10 µL of tryptic peptide solution was injected into LC–MS/MS system for protein identification.

2.6. Protein identification by LC nanoESI–Q-TOF

The diagram of the nano-scale analytical system applied in this work is shown in Fig. 2. Peptides from in-solution digestion were trapped by a desalting column and separated by a nano-flow analytical column. After on-line desalting by 0.1% FA (from pump A) for 3 min with a flow rate of 30 µL/min, the switching valve was auto-switched to analytical position. Then the tryptic peptides were separated by a nano-flow reversed-phased C18 column with a flow rate of 400 nL/min. Mobile phase B (from pump B) was 0.1% FA:ACN = 95:5 (v/v) and mobile phase C (from pump C) was 0.1% FA:ACN = 5:95 (v/v). The LC gradient conditions for peptide analysis were as follows: base on time (*t*) set at the mobile phase: *t* = 0–3 min, hold % C = 10; *t* = 3–180 min, % C from 10 to 75; *t* = 180–240 min, % C from 75 to 10. Finally the switching valve was auto-switched from the analytical position to the desalting position before the injection of the next sample.

The peptide eluate from column was directed to the nanospray source by a 20 µm i.d. and 90 µm o.d. fused-silica capillary. A volt-

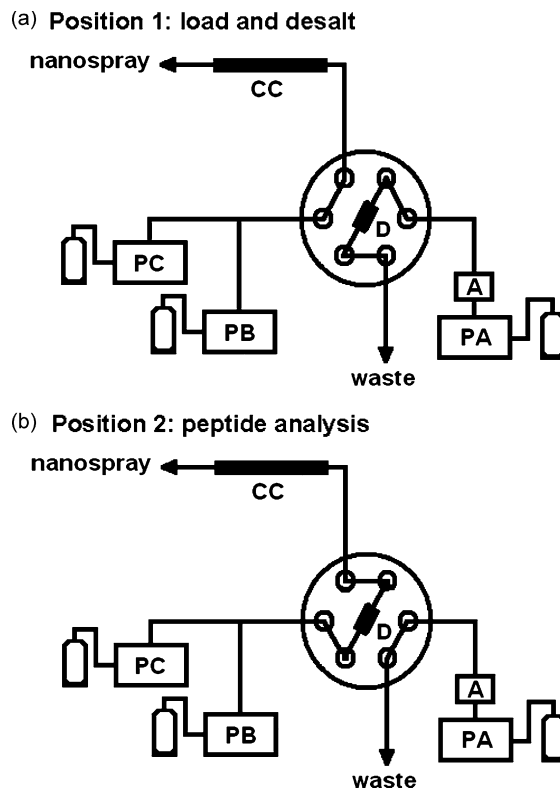

Fig. 2. The nano-scale analytical system for peptide analysis: A=autosampler; CC=nano-flow capillary column (10 cm); D=desalting column; PA=pump A; PB=pump B; PC=pump C.

age of 3.2 kV was applied to the nanosource capillary. The MS was worked in positive ion mode with a cone voltage of 80 V and a source temperature of 80 °C. TOF analyzer was set in the V-mode. MS/MS spectra were acquired in a data-dependent acquisition mode in which the two multiply-charged (+2 and +3) peaks with the three most abundant ions were selected for CID. MS/MS spectra were collected for each of these top three ions. The precursor ion was excluded if the same molecular mass ion was detected within 7 s. During the auto survey of MS and MS/MS scans, collision energies were set at 10 and 30 V using argon as the collision gas. Individual fragment spectra obtained for each of the precursors were processed by using MassLynx 4.0 software to obtain centroid MS/MS data and the corresponding peak lists in the format of pkl files. These peak list files were then submitted to MASCOT (<http://www.matrixscience.com>) search engine to get corresponding protein identity. The MASCOT program was set with the following parameters: database, NCBI nr; taxonomy, Homo sapiens; enzyme, trypsin; peptide mass tolerance, 1.2 Da; MS/MS ion mass tolerance, 0.6 Da; peptide charge, 2+ and 3+; data format, pkl; instrument, ESI–QUAD-TOF. Variable modifications such as oxidation of methionine and carbamidomethylation of cysteine were selected, and up to one missed cleavage was allowed.

3. Results and discussion

In this nano-scale analytical system, we used isocratic chromatography to elute valsartan and IS simultaneously. First valsartan and IS were loaded by pump A and retained on the RP C18 stationary phase of the nano-flow column. The mobile phase for the sample loading was ACN:1% FA = 20:80 (v/v) employed at a flow rate of 3 µL/min. The loading time was 3 min in order to eliminate both salts and polar compounds that were more hydrophilic than

Table 1
Timetable of nano-scale column switching system for chromatography of valsartan.

Time (min)	Valve position	Flow rate ($\mu\text{L}/\text{min}$)	
		Pump A	Pump B and C
0–3	Load	3	1
3–8	Analysis	3	1
>8	Load	3	1

valsartan and IS. Then the separation was performed on the nano-flow column with the mobile phase acetonitrile:1% FA = 80:20 (v/v). These two analytes of interest were eluted to nanospray source at a flow rate of $1 \mu\text{L}/\text{min}^{-1}$ and detected by mass spectrometer. These switching events are summarized in Table 1. In the beginning of this experiment, the mobile phase for the sample loading was only 1% FA. In addition, the limit of quantitation of valsartan was $1 \mu\text{g}/\text{mL}$. This sensitivity was insufficient for clinical detection after medication. When the mobile phase for the sample loading was changed from 1% FA to ACN:1% FA = 20:80 (v/v), the limit of quantitation of valsartan for a clinically therapeutic goal was attainable. Undesired polar substances in human plasma were washed out and ion suppression effect was excluded after modification of the mobile phase. Valsartan was more hydrophobic than these undesired compounds, and was strongly retained in the stationary phase after increase of the percentage of acetonitrile in the mobile phase. The major MS/MS fragments and spectrum of valsartan from human plasma after CID are shown in Fig. 3.

A series of samples containing different concentrations of valsartan were prepared to study the relationships between the ratio of peak area of valsartan to IS and the concentrations of valsartan. For quantitation, the product ions at m/z 436 > 235 and m/z 423 > 207 were used for valsartan and IS, respectively. The typical LC–MS/MS chromatograms of valsartan and IS from human plasma are shown in Fig. 4. To investigate the linear range of the method, a series of working solutions that contained different concentration of valsartan were analyzed. In order to improve reproducibility and accuracy, using an IS was necessary, especially in this nano-scale analytical system.

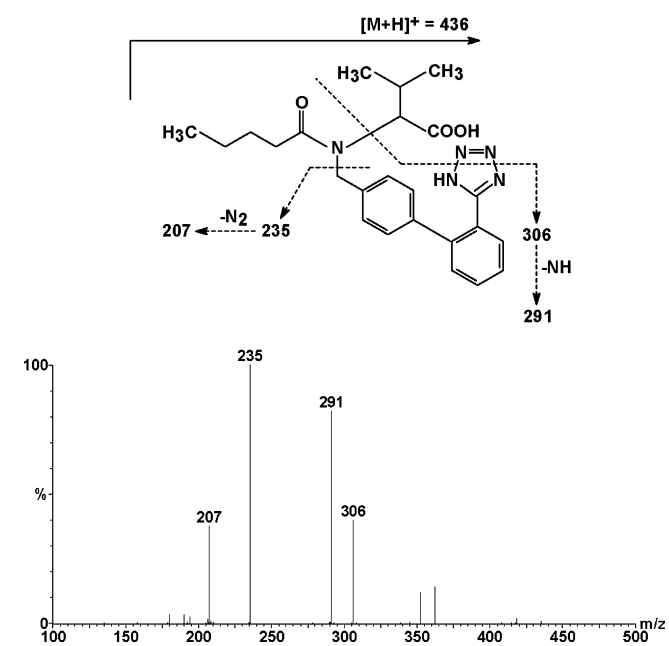

Fig. 3. Major MS/MS fragments and spectrum of valsartan.

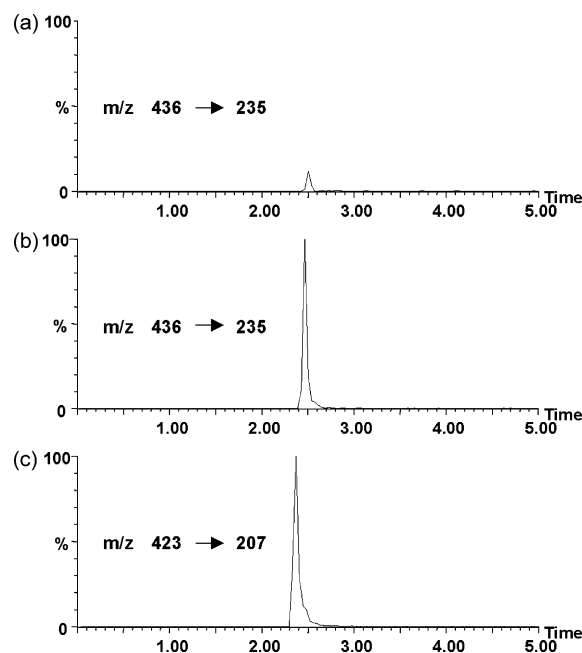

Fig. 4. Extracted LC–MS/MS chromatograms of the product ions of valsartan (m/z 436 > 235) and IS (m/z 423 > 207) from human plasma: (a) blank plasma spiked with $0.2 \mu\text{g}/\text{mL}$ valsartan; (b) blank plasma spiked with $10 \mu\text{g}/\text{mL}$ valsartan; (c) blank plasma spiked with $10 \mu\text{g}/\text{mL}$ IS. LC conditions: mobile phase of pump A was ACN:1% FA = 20:80 (v/v) at a flow rate of $3 \mu\text{L}/\text{min}$; mobile phase of pump B: pump C was 1% FA:ACN = 20:80 (v/v) at a flow rate of $1 \mu\text{L}/\text{min}$.

Quantitation was performed by integrating the peak area under the extracted ion chromatograms for valsartan (m/z 436 > 235) and IS (m/z 423 > 207) for a series of concentrations. The calibration curve for the analysis of valsartan in spiked plasma at five different levels of valsartan over the range of 0.2 – $10 \mu\text{g}/\text{mL}$ was constructed. The linearity was evaluated between the peak area ratio of valsartan to the IS as ordinate (y) and the concentration ($\mu\text{g}/\text{mL}$) of the valsartan as abscissa (x). The linear equation for the concentration vs. the ratio of peak area was $y = (0.0362 \pm 0.028)x + (0.0043 \pm 0.0029)$ with a correlation coefficient of 0.999 ($n = 5$).

The results showed that the peak area ratio was linearly related to the valsartan concentration for the range 0.2 – $10 \mu\text{g}/\text{mL}$ and good linearity was attainable. The precision (R.S.D.) and accuracy (R.E.) of the method were studied based on the peak area ratios for the analysis of valsartan at three levels, 0.4 , 2 and $8 \mu\text{g}/\text{mL}$. Table 2 indicates that the R.S.D. and R.E. values for the intra- and inter-day analyses of the spiked plasma are all below 6.7 and 4.7% , respectively. The recovery of this method ranged between 95 and 105% . The sensitiv-

Table 2
Precision and accuracy for the determination of valsartan spiked in human plasma.

Concentration known ($\mu\text{g}/\text{mL}$)	Concentration found ($\mu\text{g}/\text{mL}$)	R.S.D. (%)	R.E. ^a (%)
Intra-day ^b ($n = 5$)			
0.400	0.418 ± 0.028	6.70	+4.50
2.000	2.082 ± 0.093	4.47	+4.10
8.000	7.625 ± 0.387	5.08	-4.69
Inter-day ^c ($n = 5$)			
0.400	0.389 ± 0.025	6.43	-2.75
2.000	2.060 ± 0.097	4.71	+3.00
8.000	7.809 ± 0.435	5.57	-2.39

^a R.E. calculated from (value found-value known)/value known.

^b Intra-day assay variance from analysis of valsartan at five intervals on a single day.

^c Inter-day assay variance from analysis of valsartan on five consecutive days.

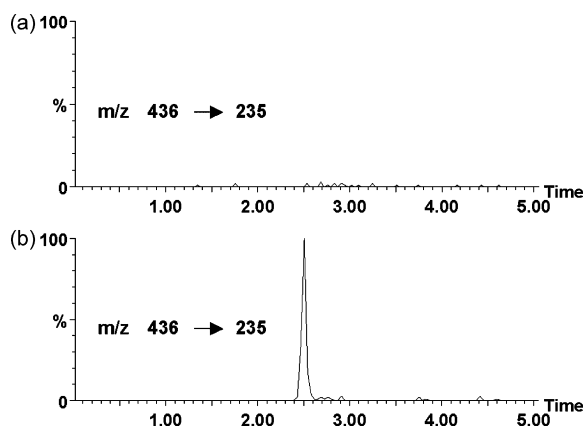

Fig. 5. LC–MS/MS chromatograms of plasma samples of a hypertensive patient after treatment with an oral dose of valsartan. (a) Plasma before dosing and (b) the plasma of a volunteer dosed with 80 mg valsartan. LC conditions were the same as in Fig. 4.

ity of this method is sufficient for monitoring valsartan in human plasma by using only 10 μ L plasma.

Reduction of amount of reagents and solvents is the key aspect of the greener approach in this study. To test its usefulness, the method developed was applied to determine the valsartan level in a hypertensive patient after pharmacological treatment. Before and after orally administering a single dose of 80 mg valsartan capsule (Diovan[®]), patient plasma sample was collected and prepared as described previously. The peak plasma concentration at 2 h after administration was about 0.84 μ g/mL. The LC–MS/MS chromatograms of valsartan from patient plasma before and after oral administration are shown in Fig. 5.

Proteomics based on clinical purpose is important and LC–MS/MS is a powerful method of identifying proteins in complex mixtures. In order to screen the hypertensive-associated proteins, 10 μ L of the patient plasma was tested. Plasma was subjected to dealbumin and precipitation treatments. For in-solution digestion, protein mixtures were reduced, alkylated, and trypsin-digested overnight. Then proteins were identified by LC–MS/MS with a nanospray source. In this preliminary study, we can find three important proteins: ANP-A receptor prepropeptide (gi|28230; matched sequence: MQLEK, VLFELKHMR, HMRDVQNEHLTR, IGIHTGPVCAGVVGLK and GDVEMKGGK), Atrial natriuretic peptide receptor B precursor (gi|113916; matched sequence: EDGLR, WEELQFGNSER and GDVEMKGGK) and C-type natriuretic peptide precursor (gi|113850; matched sequence: APGGGGANLKGDR, LLQEHNPARK, GLSKGCFGLK and IGSMSGLGC). By analysing a control sample and compare the obtained results, we cannot find these three hypertensive-related proteins. Natriuretic peptides are counterregulatory hormones that involved in the regulation of sodium and water balance, blood volume and arterial pressure. Natriuretic peptides are classified as hypotensive hormones; the main actions of natriuretic peptides are implicated in eliciting natriuretic, diuretic, steroidogenic, antiproliferative, and vasorelaxant effects, important factors in the control of body fluid volume and blood pressure homeostasis [37–39]. This result is very important information for clinical study. And we hope this simple LC–MS/MS for protein identification could be useful for clinical diagnosis.

Unexpectedly we also find a special protein, E3-MPO VL (gi|1699298) [40], which could be an important protein in microscopic polyarteritis patient. Many diseases could be cause microscopic polyarteritis, such as autoimmune diseases. After asking this patient, we get a significant answer that this patient has rheumatoid arthritis. This discover gives us a strong evidence to persuade people that proteomics is a useful technology for biomarker

screening. And LC–MS/MS for protein identification is a powerful tool for application in disease diagnosis.

4. Conclusion

A simple sample preparation procedure with LC–MS/MS method was developed for the analysis of valsartan in human plasma by solvent saving strategy. The sensitivity of this greener nano-scale analytical system is sufficient for the monitoring of valsartan plasma concentration and important protein biomarkers. The results indicate that the nano-scale analytical system coupled with RP nano-flow column and switching valve has the ability to analyze valsartan and biological important proteins. Before eluting the drug we utilized the property of valsartan, which was retained by the column up to the 20% ACN and washed out the other undesired small molecules interfering with the analysis. Application of the nano-scale method to trace analysis of valsartan and protein biomarkers is a suitable method for clinical study. Moreover, lowering the consumption of organic solvents protects our environment and is a most helpful trend toward green analytical chemistry.

Acknowledgements

The authors are grateful to the National Science Council (NSC 96-2113-M-037-015 and NSC 96-2113-M-037-016), Kaohsiung Medical University (Q-097021, Q-097028), Changhua Christian Hospital (97-CCH-KMU-009), Center of Excellence for Environmental Medicine (Kaohsiung Medical University) and National Sun Yat-Sen University-Kaohsiung Medical University Joint Research Center for financial support of this work. The authors are also grateful to the Center for Resources, Research and Development (Kaohsiung Medical University) for instrumental support of this work.

References

- [1] S. Alwan, J.E. Polifka, J.M. Friedman, *Birth Defects Res. A* 73 (2005) 123–130.
- [2] C. Schaefer, *Birth Defects Res. A* 67 (2003) 591–594.
- [3] N. Berkane, P. Carlier, L. Verstraete, E. Mathieu, N. Heim, S. Uzan, *Birth Defects Res. A* 70 (2004) 547–549.
- [4] J. Macek, J. Klíma, P. Ptáček, *J. Chromatogr. B* 832 (2006) 169–172.
- [5] M.A. Ritter, C.I. Furtek, M.W. Lo, *J. Pharm. Biomed. Anal.* 15 (1997) 1021–1029.
- [6] L. González, J.A. López, R.M. Alonso, R.M. Jiménez, *J. Chromatogr. A* 949 (2002) 49–60.
- [7] N. Daneshmandi, R.Z. Lewanczuk, F. Jamali, *J. Chromatogr. B* 766 (2002) 345–349.
- [8] D. Farthing, D. Sica, I. Fakhry, A. Pedro, T.W.B. Gehr, *J. Chromatogr. B* 704 (1997) 374–378.
- [9] J. Nie, M. Zhang, Y. Fan, Y. Wen, B. Xiang, Y.Q. Feng, *J. Chromatogr. B* 828 (2005) 62–69.
- [10] A. Soldner, H. Spahn-Langguth, E. Mutschler, *J. Pharm. Biomed. Anal.* 16 (1998) 863–873.
- [11] D.L. Hertzog, J.F. McCafferty, X. Fang, R.J. Tyrrell, R.A. Reed, *J. Pharm. Biomed. Anal.* 30 (2002) 747–760.
- [12] G. Carlucci, G. Palumbo, P. Mazzeo, M.G. Quaglia, *J. Pharm. Biomed. Anal.* 23 (2000) 185–189.
- [13] R.C. Williams, M.S. Alasandro, V.L. Fasone, R.J. Boucher, J.F. Edwards, *J. Pharm. Biomed. Anal.* 14 (1996) 1539–1546.
- [14] S. Tatar, S. Sağlık, *J. Pharm. Biomed. Anal.* 30 (2002) 371–375.
- [15] M.M. Baing, V.V. Vaidya, R.T. Sane, S.N. Menon, K. Dalvi, *Chromatographia* 64 (2006) 293–296.
- [16] G. Iriarte, N. Ferreirós, I. Ibarrondo, R.M. Alonso, M.I. Maguregi, L. Gonzalez, R.M. Jiménez, *J. Sep. Sci.* 29 (2006) 2265–2283.
- [17] L. González, U. Akesolo, R.M. Jiménez, R.M. Alonso, *Electrophoresis* 23 (2002) 223–229.
- [18] M.G. Quaglia, E. Donati, G. Carlucci, P. Mazzeo, S. Fanali, *J. Pharm. Biomed. Anal.* 29 (2002) 981–987.
- [19] S. Hillaert, W. Van den Bossche, *J. Chromatogr. A* 979 (2002) 323–333.
- [20] S. Hillaert, T.R.M. De Beer, J.O. De Beer, W. Van den Bossche, *J. Chromatogr. A* 984 (2003) 135–146.
- [21] S. Hillaert, W. Van den Bossche, *J. Pharm. Biomed. Anal.* 31 (2003) 329–339.
- [22] M. Zhang, F. Wei, Y.F. Zhang, J. Nie, Y.Q. Feng, *J. Chromatogr. A* 1102 (2006) 294–301.

- [23] N. Koseki, H. Kawashita, H. Hara, M. Niina, M. Tanaka, R. Kawai, Y. Nagae, N. Masuda, *J. Pharm. Biomed. Anal.* 43 (2007) 1769–1774.
- [24] T. Iwasa, T. Takano, K.I. Hara, T. Kamei, *J. Chromatogr. B* 734 (1999) 325–330.
- [25] B.M. Chen, Y.Z. Liang, Y.L. Wang, F.L. Deng, P. Zhou, F.Q. Guo, L.F. Huang, *Anal. Chim. Acta* 540 (2005) 367–373.
- [26] M. Polinko, K. Riffel, H. Song, M.W. Lo, *J. Pharm. Biomed. Anal.* 33 (2003) 73–84.
- [27] Z. Zhao, Q. Wang, E.W. Tsai, X.Z. Qin, D. Ip, *J. Pharm. Biomed. Anal.* 20 (1999) 129–136.
- [28] R.A. Seburg, J.M. Ballard, T.L. Hwang, C.M. Sullivan, *J. Pharm. Biomed. Anal.* 42 (2006) 411–422.
- [29] D.A. Wolters, M.P. Washburn, J.R. Yates III, *Anal. Chem.* 73 (2001) 5683–5690.
- [30] C.C. Wu, M.J. MacCoss, K.E. Howell, J.R. Yates III, *Nat. Biotechnol.* 21 (2003) 532–538.
- [31] H.J. Lee, E.Y. Lee, M.S. Kwon, Y.K. Paik, *Curr. Opin. Chem. Biol.* 10 (2006) 42–49.
- [32] D.F. Hochstrasser, J.C. Sanchez, R.D. Appel, *Proteomics* 2 (2002) 807–812.
- [33] M. Mann, R.C. Hendrickson, A. Pandey, *Annu. Rev. Biochem.* 70 (2001) 437–473.
- [34] M.J. Chalmers, S.J. Gaskell, *Curr. Opin. Biotechnol.* 11 (2000) 384–390.
- [35] J. Namieśnik, *J. Sep. Sci.* 24 (2001) 151–153.
- [36] P.T. Anastas, M.M. Kirchhoff, *Acc. Chem. Res.* 35 (2002) 686–694.
- [37] K.N. Pandey, *Peptides* 26 (2005) 901–932.
- [38] T. Nishikimi, N. Maeda, H. Matsuoka, *Cardiovasc. Res.* 69 (2006) 318–328.
- [39] T. Suzuki, T. Yamazaki, Y. Yazaki, *Cardiovasc. Res.* 51 (2001) 489–494.
- [40] C. Longhurst, M.R. Ehrenstein, B. Leaker, F.K. Stevenson, M. Spellerberg, C. Chapman, D. Latchmen, D.A. Isenberg, *G. Cambridge, Immunology* 87 (1996) 334–338.